



IMSA
INSTALACIONES Y MAQUINARIA

MAQUINARIA SEMINUEVA

SCOOPTRAM DERIU

**CONDICIÓN:
SEMINUEVO**

**Modelo: DERIU
DRWJ-1.5**

**Capacidad:
2 Yardas**



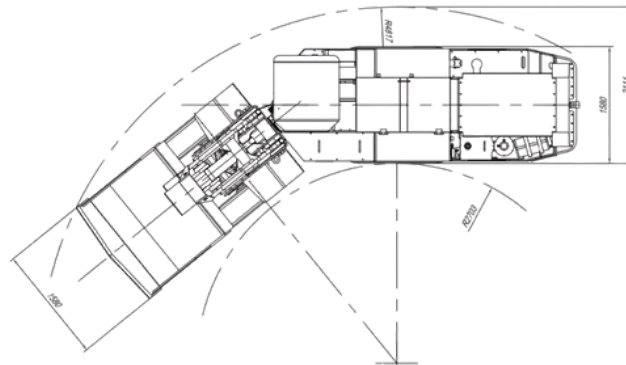
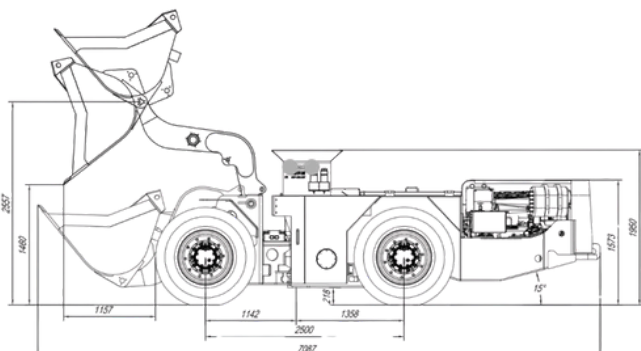

Motor:

Deutz F6L914

Transmisión

Dana Motor 32,000

Convertidor

Dana C270

Ejes:

Dana 12D

Capacidad:

2 YD

| No. | item | parameters | remark |
|-----|--------------------------------|---|-------------|
| 1 | Bucket capacity | 1.5m ³ (2.0 yd ³) (1.3-1.5m ³ is optional, depends on density of mineral) | Heaped, SAE |
| 2 | Rated tramming capacity | 3.3 ton | |
| 3 | Max. dump height | 1410-1460mm | |
| 4 | Min.dump distance | 1020-1157mm | |
| 5 | Min.ground clearance | 218-230mm | |
| 6 | Max.dump angle | ≥ 45° | |
| 7 | Angle of departure | 15° | |
| 8 | Gradeability | 14° | |
| 9 | Max Lifting capacity | ≥ 4.5 t | |
| 10 | Steering angle | ± 40° | |
| 11 | Max.breakout force | ≥ 87KN | |
| 12 | Max.tractive force | ≥ 93KN | |
| 15 | Degree of Oscillation | ± 8° | |
| 16 | Turning radius(inside、outside) | Type A — inside ≤ 2607, outside ≤ 4777mm Type B — inside ≤ 2703, outside ≤ 4817mm | |
| 17 | Total weight | (10.3 ± 0.5) t | |
| 18 | Overall dimensions | Type A — length: 6643mm Type B — length: 7087mm | |
| | | Type A : width of main frame: 1500-1600 mm width of bucket: 1520-1760 mm Type A : width of main frame: 1520 mm width of bucket: 1580 mm Height: 2050 mm | |